

evoflow[®]

HIGH PERFORMANCE PUMPS



- ✓ High Flow Rates
- ✓ Low Noise Operation
- ✓ Engineered for Efficiency
- ✓ Secondary Motor Seal
- ✓ 3 Year Warranty

TUF SERIES PUMPS

evolution[®]

WATER & LIGHTING SOLUTIONS

www.evolutionwls.com.au

Evoflow Tuf Series pumps are ideal for large domestic swimming pools with ancillary systems such as heating, in-floor cleaning, fountains, vacuum cleaning and swim jets. Tuf Series pumps have been designed for optimal hydraulic performance and are built to the highest quality standards.

The Evoflow TUF Advantage

- Engineered for performance and reliability even in the toughest Australian conditions.
- Ideal for large domestic swimming pools with ancillary systems such as heating, in-floor cleaning, fountains and swim jets.
- Impeller and diffuser design maximises hydraulic output and minimises turbulence.
- Efficient hydraulic performance shortens run times and reduces energy consumption leading to lower operating costs.
- Strong, thick walled, one piece pump body moulded from a high grade engineering thermoplastic that is corrosion resistant.
- High grade 316 stainless steel mechanical seal incorporated for extra protection against corrosion, ideal for chlorinated salt water.
- Unique secondary seal between the pump wet end and motor prevents any water entering the motor if the mechanical seal is worn out.
- Powerful and reliable fan cooled motor, designed and rated for continuous operation ensures a long bearing life.
- Built in thermal overload protects the motor against damage from overheating.
- Easy to remove inspection lid for simple routine maintenance and cleaning of leaf basket.
- Self aligning 50mm barrel unions allows for quick and easy installation and removal.

Specifications

Model	HP	Flow Rate @ 8m Head	Volts / Phase	Full Load Amps	Watts Input	Inlet / Outlet (mm)	Length of Pump (A)
TUF100	1.00	275	240/1	3.70	840	50	602
TUF150	1.50	355	240/1	5.30	1150	50	623
TUF200	2.00	465	240/1	7.20	1500	50	663

TUF Series Performance

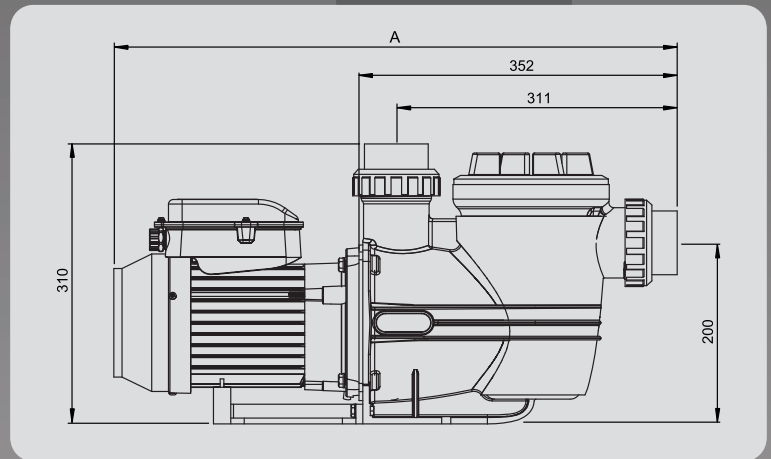
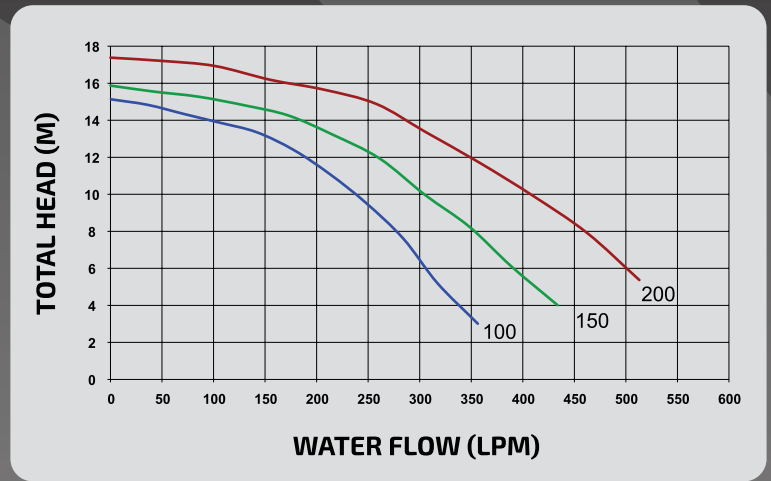

Warranty

- 3 year limited warranty.
- 12 months for commercial installations.